

DESPIECE

REV: 0

1645

FECHA: 21/12/2021

HOJA: 1/3

CODIGO 75311, 75312, 75313

DESCRIPCION: BOMBA DE CALOR FSN-08-10-12

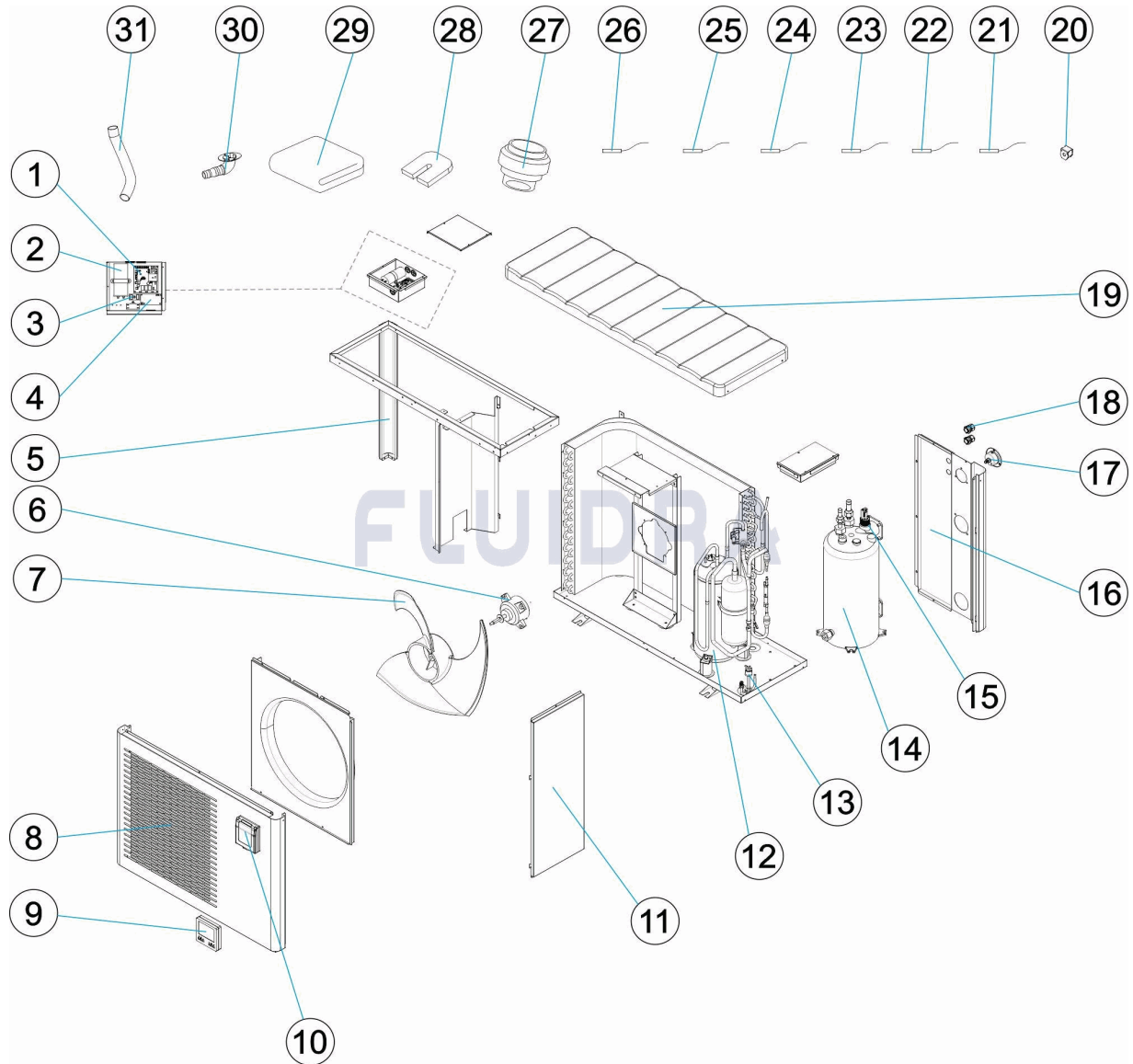

ESPAÑOL

POS	CODIGO	DESCRIPCION	CANTIDAD	POS	CODIGO	DESCRIPCION	CANTIDAD
1	75311R0019	CONDENSADOR MOTOR VENTILADOR		12	* 75311R0009	COMPRESOR	
2	* 75311R0018	CONDENSADOR MOTOR VENTILADOR		12	* 75313R0009	COMPRESOR	
2	* 75313R0018	CONDENSADOR MOTOR VENTILADOR		13	75311R0007	DETECTOR DE PRESIÓN BAJA	
3	75311R0021	PLACA BASE PCB		14	* 75311R0006	INTERCAMBIADOR DE TITANIO	
4	75311R0022	PLACA TRANSFORMADOR		14	* 75312R0006	INTERCAMBIADOR DE TITANIO	
5	75311R0017	PILAR		14	* 75313R0006	INTERCAMBIADOR DE TITANIO	
6	* 75311R0015	MOTOR VENTILADOR		15	75311R0005	FLUJOSTATO	
6	* 75313R0015	MOTOR VENTILADOR		16	* 75311R0004	PANEL TRASERO	
7	* 75311R0014	ASPAS VENTILADOR		16	* 75313R0004	PANEL TRASERO	
7	* 75313R0014	ASPAS VENTILADOR		17	75311R0003	MANOMETRO	
8	* 75311R0013	PANEL FRONTAL		18	75311R0002	PRENSAESTOPAS	
8	* 75313R0013	PANEL FRONTAL		19	* 75311R0001	TAPA SUPERIOR	
9	75311R0012	CAJA CONTROLADOR IMPERMEABLE		19	* 75313R0001	TAPA SUPERIOR	

* NOTA OBSERVACIONES

DESPIECE

REV: 0

1645

FECHA: 21/12/2021

HOJA: 2/3

CODIGO **75311, 75312, 75313**DESCRIPCION: **BOMBA DE CALOR FSN-08-10-12**

10	75311R0011	CONTROLADOR	20	75311R0023	BOBINA VALVULA DE 4 VIAS
11	75311R0010	PANEL DERECHO	21	75311R0024	SENSOR TEMPERATURA SUCCIÓN GAS
22	75311R0026	SENSOR TEMPERATURA SORTIDA AIGUA	28	75311R0035	PIES ANTIVIBRATORIOS
23	75311R0028	SENSOR TEMPERATURA ENTRADA AGUA	29	* 75311R0036	CUBIERTA DE INVIERNO
24	75311R0029	SENSOR TEMPERATURA AMBIENTE	29	* 75313R0036	CUBIERTA DE INVIERNO
25	75311R0030	SENSOR TEMPERATURA EVAPORADOR	30	75311R0034	BOQUILLA DE AGUA
26	75311R0031	SENSOR TEMPERATURA DESCARGA GAS	31	75311R0033	MANGUERA DE DRENAJE
27	75311R0032	KIT DE CONEXIÓN AGUA			

DESPIECE

REV: 0
FECHA: 21/12/2021
HOJA: 3/3

1645

CODIGO **75311, 75312, 75313**

DESCRIPCION: **BOMBA DE CALOR FSN-08-10-12**

OBSERVACIONES

POS	CODIGO	OBSERVACIONES
2	* 75311R0018	PARA: 75311, 75312
2	* 75313R0018	PARA: 75313
6	* 75311R0015	PARA: 75311, 75312
6	* 75313R0015	PARA: 75313
7	* 75311R0014	PARA: 75311, 75312
7	* 75313R0014	PARA: 75313
8	* 75311R0013	PARA: 75311, 75312
8	* 75313R0013	PARA: 75313
12	* 75311R0009	PARA: 75311, 75312
12	* 75313R0009	PARA: 75313
14	* 75311R0006	PARA: 75311
14	* 75312R0006	PARA: 75312
14	* 75313R0006	PARA: 75313
16	* 75311R0004	PARA: 75311, 75312
16	* 75313R0004	PARA: 75313
19	* 75311R0001	PARA: 75311, 75312
19	* 75313R0001	PARA: 75313
29	* 75311R0036	PARA: 75311, 75312
29	* 75313R0036	PARA: 75313

ÉCLATÉ

REV.: 0

1645

DATE: 21/12/2021

PAG.: 1/3

CODE 75311, 75312, 75313

DESCRIPTION: POMPE À CHALEUR FSN-08-10-12

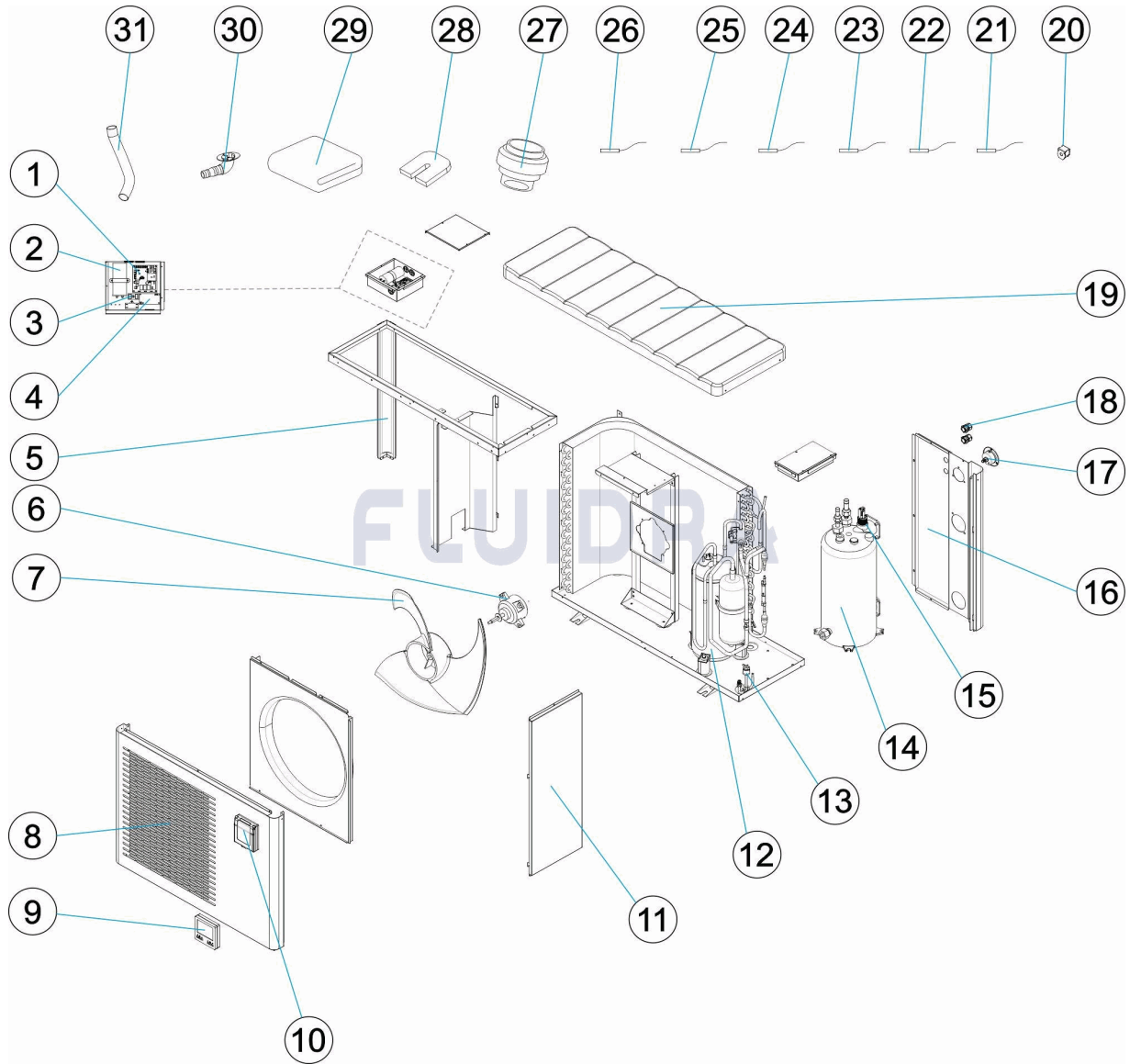

FRANCAIS

POS	CODE	DESCRIPTION	QUANTITE	POS	CODE	DESCRIPTION	QUANTITE
1	75311R0019	CONDENSATEUR MOTEUR VENTILATEUR		12	* 75311R0009	COMPRESSEUR	
2	* 75311R0018	CONDENSATEUR MOTEUR VENTILATEUR		12	* 75313R0009	COMPRESSEUR	
2	* 75313R0018	CONDENSATEUR MOTEUR VENTILATEUR		13	75311R0007	DÉTECTEUR BASSE PRESSION	
3	75311R0021	PLAQUE BASE PCB		14	* 75311R0006	ÉCHANGEUR EN TITANE	
4	75311R0022	CARTE TRANSFORMATEUR		14	* 75312R0006	ÉCHANGEUR EN TITANE	
5	75311R0017	PILIER		14	* 75313R0006	ÉCHANGEUR EN TITANE	
6	* 75311R0015	MOTEUR VENTILATEUR		15	75311R0005	CONTROLEUR DE DEBIT	
6	* 75313R0015	MOTEUR VENTILATEUR		16	* 75311R0004	PANNEAU ARRIÈRE	
7	* 75311R0014	PALES VENTILATEUR		16	* 75313R0004	PANNEAU ARRIÈRE	
7	* 75313R0014	PALES VENTILATEUR		17	75311R0003	MANOMETRE	
8	* 75311R0013	PANNEAU AVANT		18	75311R0002	PRESSE-ÉTOUPES	
8	* 75313R0013	PANNEAU AVANT		19	* 75311R0001	COUVERCLE SUPÉRIEUR	
9	75311R0012	BOÎTIER CONTRÔLEUR ÉTANCHE		19	* 75313R0001	COUVERCLE SUPÉRIEUR	

* VOIR FICHE D'OBSERVATIONS

ÉCLATÉ

REV.: 0

1645

DATE: 21/12/2021

PAG.: 2/3

CODE **75311, 75312, 75313**DESCRIPTION: **POMPE À CHALEUR FSN-08-10-12**

10	75311R0011	CONTRÔLEUR	20	75311R0023	BOBINE VANNE 4 VOIES
11	75311R0010	PANNEAU DROIT	21	75311R0024	CAPTEUR TEMPÉRATURE ASPIRATION GA
22	75311R0026	CAPTEUR TEMPÉRATURE EAU SORTIE	28	75311R0035	PIEDS ANTI-VIBRATION
23	75311R0028	CAPTEUR TEMPÉRATURE ARRIVÉE D'EAU	29	* 75311R0036	COUVERTURE D'HIVERNAGE
24	75311R0029	CAPTEUR TEMPÉRATURE AMBIANT	29	* 75313R0036	COUVERTURE D'HIVERNAGE
25	75311R0030	CAPTEUR TEMPÉRATURE ÉVAPORATEUR	30	75311R0034	BUSE D'EAU
26	75311R0031	CAPTEUR TEMPÉRATURE DÉCHARGE GA	31	75311R0033	TUYAU DE DRAINAGE
27	75311R0032	ENSEMBLES CONNEXION D'EAU			

ÉCLATÉ

REV.: 0

1645

DATE: 21/12/2021

PAG.: 3/3

CODE 75311, 75312, 75313

DESCRIPTION: POMPE À CHALEUR FSN-08-10-12

OBSERVATIONS

POS	CODE	OBSERVATIONS
2	* 75311R0018	POUR: 75311, 75312
2	* 75313R0018	POUR: 75313
6	* 75311R0015	POUR: 75311, 75312
6	* 75313R0015	POUR: 75313
7	* 75311R0014	POUR: 75311, 75312
7	* 75313R0014	POUR: 75313
8	* 75311R0013	POUR: 75311, 75312
8	* 75313R0013	POUR: 75313
12	* 75311R0009	POUR: 75311, 75312
12	* 75313R0009	POUR: 75313
14	* 75311R0006	POUR: 75311
14	* 75312R0006	POUR: 75312
14	* 75313R0006	POUR: 75313
16	* 75311R0004	POUR: 75311, 75312
16	* 75313R0004	POUR: 75313
19	* 75311R0001	POUR: 75311, 75312
19	* 75313R0001	POUR: 75313
29	* 75311R0036	POUR: 75311, 75312
29	* 75313R0036	POUR: 75313

PARTS BREAKDOWN

REV.: 0
DATE: 21/12/2021
SHEET: 1/3

1645

CODE 75311, 75312, 75313

DESCRIPTION: HEAT PUMP FSN-08-10-12

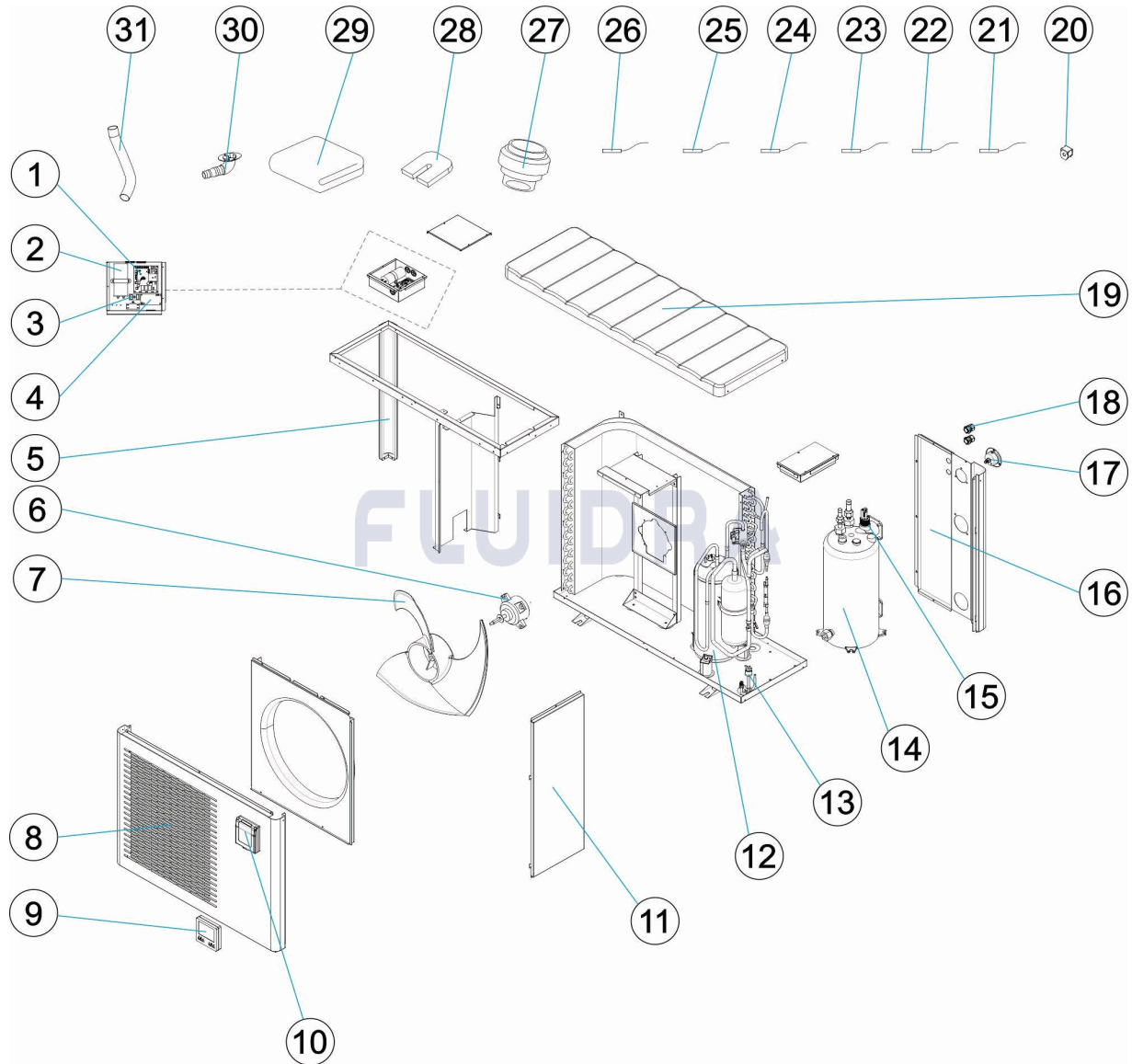

ENGLISH

POS	CODE	DESCRIPTION	QUANTITY	POS	CODE	DESCRIPTION	QUANTITY
1	75311R0019	FAN MOTOR CAPACITANCE		12	* 75311R0009	COMPRESSORE	
2	* 75311R0018	FAN MOTOR CAPACITANCE		12	* 75313R0009	COMPRESSORE	
2	* 75313R0018	FAN MOTOR CAPACITANCE		13	75311R0007	LOW PRESSURE SWITCH	
3	75311R0021	PC BOARD		14	* 75311R0006	TITANIUM HEAT EXCHANGER	
4	75311R0022	TRANSFORMER BOARD		14	* 75312R0006	TITANIUM HEAT EXCHANGER	
5	75311R0017	PILLAR		14	* 75313R0006	TITANIUM HEAT EXCHANGER	
6	* 75311R0015	FAN MOTOR		15	75311R0005	WATER FLOW SWITCH	
6	* 75313R0015	FAN MOTOR		16	* 75311R0004	BACK PANEL	
7	* 75311R0014	FAN BLADE		16	* 75313R0004	BACK PANEL	
7	* 75313R0014	FAN BLADE		17	75311R0003	PRESSURE GAUGE	
8	* 75311R0013	FRONT PANEL		18	75311R0002	CABLE GLANDS	
8	* 75313R0013	FRONT PANEL		19	* 75311R0001	TOP COVER	
9	75311R0012	WATERPROOF CONTROLLER BOX		19	* 75313R0001	TOP COVER	

* SEE OBSERVATIONS SHEET

PARTS BREAKDOWN

REV.: 0
DATE: 21/12/2021
SHEET: 2/3

1645

CODE 75311, 75312, 75313

DESCRIPTION: HEAT PUMP FSN-08-10-12

10	75311R0011	CONTROLLER	20	75311R0023	4-WAY VALVE COIL
11	75311R0010	RIGHT PANEL	21	75311R0024	GAS SUCTION TEMPERATURE SENSOR
22	75311R0026	WATER OUTLET TEMPERATURE SENSOR	28	75311R0035	ANTI-VIBRATION FEET
23	75311R0028	WATER INLET TEMPERATURE SENSOR	29	* 75311R0036	WINTER COVER
24	75311R0029	AMBIENT TEMPERATURE SENSOR	29	* 75313R0036	WINTER COVER
25	75311R0030	WATER INLET TEMPERATURE EVAPORATC	30	75311R0034	WATER NOZZLE
26	75311R0031	GAS DISCHARGE TEMPERATURE SENSO	31	75311R0033	DRAIN HOSE
27	75311R0032	WATER CONNECTION SETS			

* SEE OBSERVATIONS SHEET

PARTS BREAKDOWN

REV.: 0

1645

DATE: 21/12/2021

SHEET: 3/3

CODE 75311, 75312, 75313

DESCRIPTION: HEAT PUMP FSN-08-10-12

OBSERVATIONS

POS	CODE	OBSERVATIONS
2	* 75311R0018	FOR: 75311, 75312
2	* 75313R0018	FOR: 75313
6	* 75311R0015	FOR: 75311, 75312
6	* 75313R0015	FOR: 75313
7	* 75311R0014	FOR: 75311, 75312
7	* 75313R0014	FOR: 75313
8	* 75311R0013	FOR: 75311, 75312
8	* 75313R0013	FOR: 75313
12	* 75311R0009	FOR: 75311, 75312
12	* 75313R0009	FOR: 75313
14	* 75311R0006	FOR: 75311
14	* 75312R0006	FOR: 75312
14	* 75313R0006	FOR: 75313
16	* 75311R0004	FOR: 75311, 75312
16	* 75313R0004	FOR: 75313
19	* 75311R0001	FOR: 75311, 75312
19	* 75313R0001	FOR: 75313
29	* 75311R0036	FOR: 75311, 75312
29	* 75313R0036	FOR: 75313

ESPLOSO

REV.: 0

1645

DATA: 21/12/2021

PAG.: 1/3

CODICE 75311, 75312, 75313

DESCRIZIONE: POMPA DI CALORE FSN-08-10-12

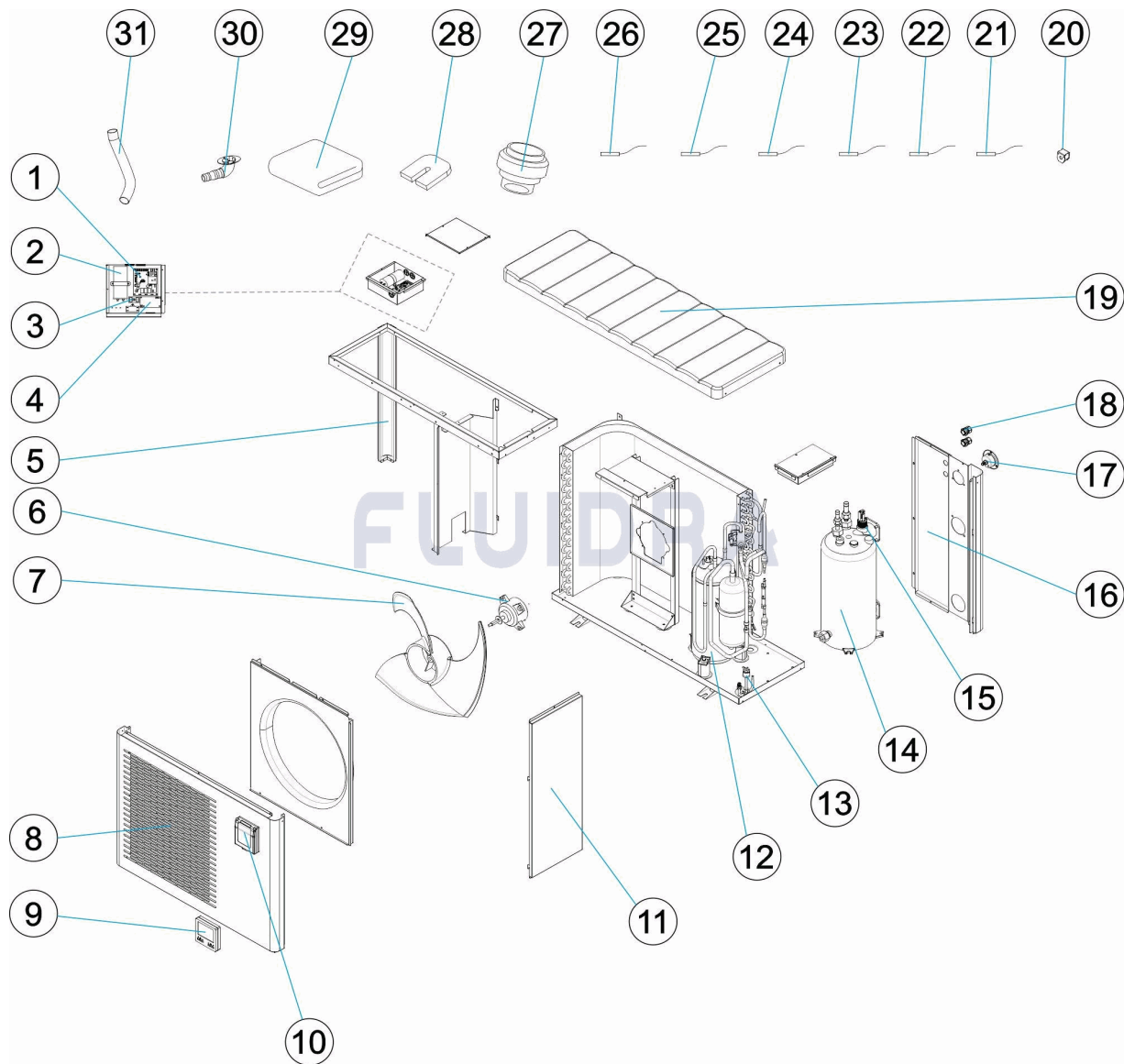

ITALIANO

POS	CODICE	DESCRIZIONE	QUANTITA'	POS	CODICE	DESCRIZIONE	QUANTITA'
1	75311R0019	CONDENSATORE MOTORE VENTOLA		12	* 75311R0009	COMPRESSORE	
2	* 75311R0018	CONDENSATORE MOTORE VENTOLA		12	* 75313R0009	COMPRESSORE	
2	* 75313R0018	CONDENSATORE MOTORE VENTOLA		13	75311R0007	RIVELATORE BASSO PRESSIONE	
3	75311R0021	SCHEDA BASE PCB		14	* 75311R0006	INTERCAMBIATORE IN TITANIO	
4	75311R0022	SCHEDA TRASFORMAZIONE		14	* 75312R0006	INTERCAMBIATORE IN TITANIO	
5	75311R0017	PILASTRO		14	* 75313R0006	INTERCAMBIATORE IN TITANIO	
6	* 75311R0015	MOTORE VENTOLA		15	75311R0005	FLUSSOSTATO	
6	* 75313R0015	MOTORE VENTOLA		16	* 75311R0004	PANNELLO INDIETRO	
7	* 75311R0014	PALE VENTILATORE		16	* 75313R0004	PANNELLO INDIETRO	
7	* 75313R0014	PALE VENTILATORE		17	75311R0003	MANOMETRO	
8	* 75311R0013	PANNELLO FRONTALE		18	75311R0002	PRESSACAVI	
8	* 75313R0013	PANNELLO FRONTALE		19	* 75311R0001	COPERCHIO SUPERIORE	
9	75311R0012	SCATOLA CONTROLLO IMPERMEABILE		19	* 75313R0001	COPERCHIO SUPERIORE	

* SI FACCIA RIFERIMENTO AL FOGLIO DELLE OSSERVAZIONI

ESPLOSO

REV.: 0
DATA: 21/12/2021
PAG.: 2/3

1645

CODICE **75311, 75312, 75313**

DESCRIZIONE: **POMPA DI CALORE FSN-08-10-12**

10	75311R0011	CONTROLLATORE	20	75311R0023	BOBINA VALVOLA A 4 VIE
11	75311R0010	PANNELLO DESTRO	21	75311R0024	SENSORE TEMPERATURA ASPIRAZIONE G
22	75311R0026	SENSORE TEMPERATURA USCITA ACQUA	28	75311R0035	PIEDINI ANTIVIBRAZIONE
23	75311R0028	SENSORE TEMPERATURA INGRESSO ACC	29	* 75311R0036	COPERTA DI INVERNO
24	75311R0029	SENSORE TEMPERATURA AMBIENTE	29	* 75313R0036	COPERTA DI INVERNO
25	75311R0030	SENSORE TEMPERATURA EVAPORATORE	30	75311R0034	UGELLO DELL'ACQUA
26	75311R0031	SENSORE TEMPERATURA SCARICO GAS	31	75311R0033	TUBO DI SCARICO
27	75311R0032	SET CONNESSIONE DELL'ACQUA			

* SI FACCIA RIFERIMENTO AL FOGLIO DELLE OSSERVAZIONI

ESPLOSO

REV.: 0
DATA: 21/12/2021
PAG.: 3/3

1645

CODICE **75311, 75312, 75313**

DESCRIZIONE: **POMPA DI CALORE FSN-08-10-12**

OSSERVAZIONI

POS	CODICE	OSSERVAZIONI
2	* 75311R0018	PER: 75311, 75312
2	* 75313R0018	PER: 75313
6	* 75311R0015	PER: 75311, 75312
6	* 75313R0015	PER: 75313
7	* 75311R0014	PER: 75311, 75312
7	* 75313R0014	PER: 75313
8	* 75311R0013	PER: 75311, 75312
8	* 75313R0013	PER: 75313
12	* 75311R0009	PER: 75311, 75312
12	* 75313R0009	PER: 75313
14	* 75311R0006	PER: 75311
14	* 75312R0006	PER: 75312
14	* 75313R0006	PER: 75313
16	* 75311R0004	PER: 75311, 75312
16	* 75313R0004	PER: 75313
19	* 75311R0001	PER: 75311, 75312
19	* 75313R0001	PER: 75313
29	* 75311R0036	PER: 75311, 75312
29	* 75313R0036	PER: 75313

EINZELTEILE

ÜBER.: 0

1645

DATUM: 21/12/2021

BLATT: 1/3

CODE 75311, 75312, 75313

BESCHREIBUNG: WÄRMEPUMPE FSN-08-10-12

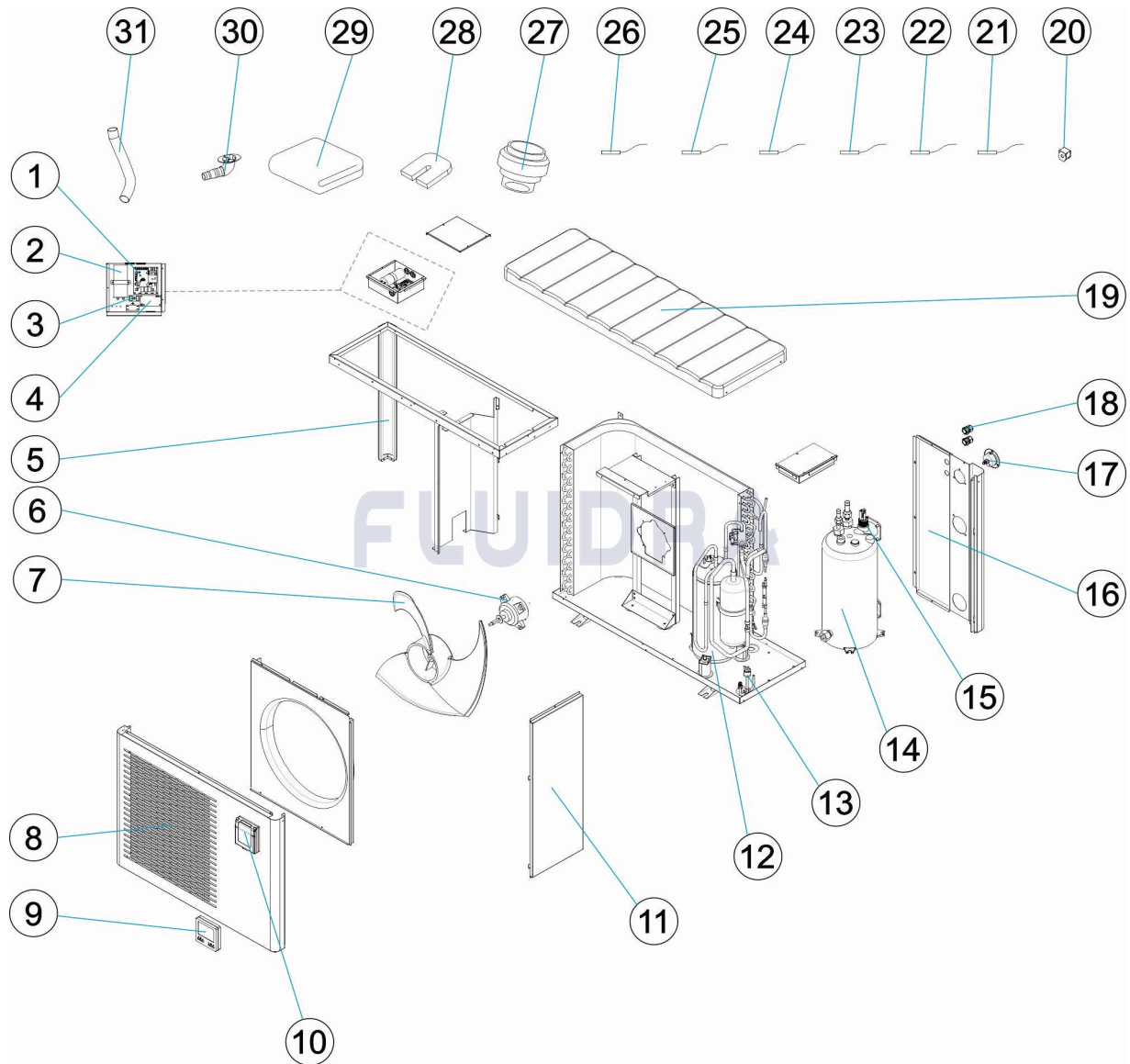

DEUTSCH

POS	CODE	BESCHREIBUNG	MENGE	POS	CODE	BESCHREIBUNG	MENGE
1	75311R0019	LÜFTERMOTOR KONDENSATOR		12	* 75311R0009	KOMPRESSOR	
2	* 75311R0018	LÜFTERMOTOR KONDENSATOR		12	* 75313R0009	KOMPRESSOR	
2	* 75313R0018	LÜFTERMOTOR KONDENSATOR		13	75311R0007	DETEKTOR NIEDERDRUCK	
3	75311R0021	BASISPLATTE PCB		14	* 75311R0006	WÄRMEÜBERTRAGER TITANIUM	
4	75311R0022	PLATTEN TRANSFORMATOR		14	* 75312R0006	WÄRMEÜBERTRAGER TITANIUM	
5	75311R0017	SÄULE		14	* 75313R0006	WÄRMEÜBERTRAGER TITANIUM	
6	* 75311R0015	LÜFTERMOTOR		15	75311R0005	DURCHFLUSSMESSER	
6	* 75313R0015	LÜFTERMOTOR		16	* 75311R0004	FÜHRERHAUSRÜCKWAND	
7	* 75311R0014	ROTORBLÄTTER VENTILATOR		16	* 75313R0004	FÜHRERHAUSRÜCKWAND	
7	* 75313R0014	ROTORBLÄTTER VENTILATOR		17	75311R0003	MANOMETER	
8	* 75311R0013	FRONTPLATTE		18	75311R0002	KABELVERSCHRAUBUNGEN	
8	* 75313R0013	FRONTPLATTE		19	* 75311R0001	ABDECKUNG OBEN	
9	75311R0012	WASSERDICHTER STEUERUNGSBOX		19	* 75313R0001	ABDECKUNG OBEN	

* SIEHE ANMERKUNGSBLATT

EINZELTEILE

ÜBER.: 0

1645

DATUM: 21/12/2021

BLATT: 2/3

CODE **75311, 75312, 75313**BESCHREIBUNG: **WÄRMEPUMPE FSN-08-10-12**

10	75311R0011	STEUERUNG	20	75311R0023	SPULE 4-WEGE-VENTIL
11	75311R0010	RECHTENPLATTE	21	75311R0024	GASANSAUG TEMPERATURFÜHLER
22	75311R0026	WASSERABFLUSS TEMPERATURFÜHLER	28	75311R0035	ANTI-VIBRATIONSFÜSSE
23	75311R0028	WASSERZUFLUSS TEMPERATURFÜHLER	29	* 75311R0036	WINTERDECKEL
24	75311R0029	UMGEBUNGS TEMPERATURFÜHLER	29	* 75313R0036	WINTERDECKEL
25	75311R0030	VERDAMPFER TEMPERATURFÜHLER	30	75311R0034	WASSERDÜSE
26	75311R0031	GASDAUER TEMPERATURFÜHLER	31	75311R0033	ABFLUSSSCHLAUCH
27	75311R0032	WASSERANSCHLUSS SET			

* SIEHE ANMERKUNGSBLATT

EINZELTEILE

ÜBER.: 0

1645

DATUM: 21/12/2021

BLATT: 3/3

CODE **75311, 75312, 75313**BESCHREIBUNG: **WÄRMEPUMPE FSN-08-10-12**

HINWEISE

POS	CODE	HINWEISE
2	* 75311R0018	FÜR: 75311, 75312
2	* 75313R0018	FÜR: 75313
6	* 75311R0015	FÜR: 75311, 75312
6	* 75313R0015	FÜR: 75313
7	* 75311R0014	FÜR: 75311, 75312
7	* 75313R0014	FÜR: 75313
8	* 75311R0013	FÜR: 75311, 75312
8	* 75313R0013	FÜR: 75313
12	* 75311R0009	FÜR: 75311, 75312
12	* 75313R0009	FÜR: 75313
14	* 75311R0006	FÜR: 75311
14	* 75312R0006	FÜR: 75312
14	* 75313R0006	FÜR: 75313
16	* 75311R0004	FÜR: 75311, 75312
16	* 75313R0004	FÜR: 75313
19	* 75311R0001	FÜR: 75311, 75312
19	* 75313R0001	FÜR: 75313
29	* 75311R0036	FÜR: 75311, 75312
29	* 75313R0036	FÜR: 75313

ITEM

REV.: 0

1645

DATA: 21/12/2021

FOLHA: 1/3

CODIGO 75311, 75312, 75313

DESCRIÇÃO: BOMBA DE CALOR FSN-08-10-12

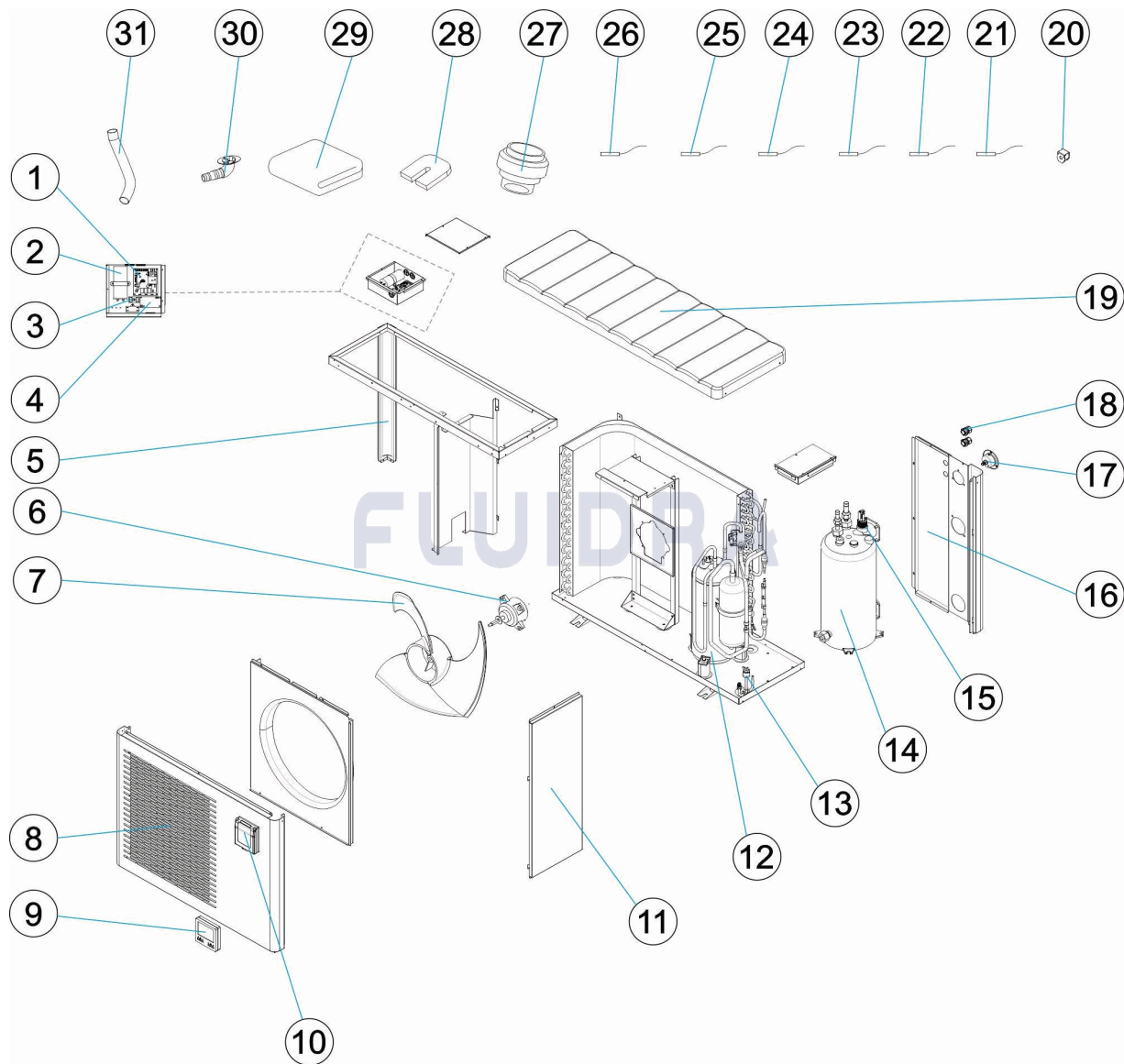

PORTUGUES

POS	CODIGO	DESCRIÇÃO	JANTIDADE	POS	CODIGO	DESCRIÇÃO	JANTIDADE
1	75311R0019	CONDENSADOR MOTOR VENTILADOR		12	* 75311R0009	COMPRESSOR	
2	* 75311R0018	CONDENSADOR MOTOR VENTILADOR		12	* 75313R0009	COMPRESSOR	
2	* 75313R0018	CONDENSADOR MOTOR VENTILADOR		13	75311R0007	DETECTOR DE BAIXA PRESSÃO	
3	75311R0021	PLACA BASE PCB		14	* 75311R0006	PERMUTADOR DE TITÂNIO	
4	75311R0022	PLACA TRANSFORMADOR		14	* 75312R0006	PERMUTADOR DE TITÂNIO	
5	75311R0017	PILAR		14	* 75313R0006	PERMUTADOR DE TITÂNIO	
6	* 75311R0015	MOTOR VENTILADOR		15	75311R0005	FLUXO-ESTATO	
6	* 75313R0015	MOTOR VENTILADOR		16	* 75311R0004	PAINEL TRASEIRO	
7	* 75311R0014	PÁS VENTILADOR		16	* 75313R0004	PAINEL TRASEIRO	
7	* 75313R0014	PÁS VENTILADOR		17	75311R0003	MANOMETRO	
8	* 75311R0013	PAINEL FRONTAL		18	75311R0002	PRENSA-CABOS	
8	* 75313R0013	PAINEL FRONTAL		19	* 75311R0001	TAMPA SUPERIOR	
9	75311R0012	CAIXA DE CONTROLE IMPERMEÁVEL		19	* 75313R0001	TAMPA SUPERIOR	

* VEJA A FICHA DE OBSERVAÇÕES

ITEM

REV.: 0

1645

DATA: 21/12/2021

FOLHA: 2/3

CODIGO **75311, 75312, 75313**DESCRIÇÃO: **BOMBA DE CALOR FSN-08-10-12**

10	75311R0011	CONTROLADOR	20	75311R0023	BOBINA VÁLVULA DE 4 VIAS
11	75311R0010	PAINEL DIREITO	21	75311R0024	SENSOR TEMPERATURA SUÇÃO GÁS
22	75311R0026	SENSOR TEMPERATURA SAÍDA ÁGUA	28	75311R0035	PÉS ANTIVIBRAÇÃO
23	75311R0028	SENSOR TEMPERATURA ENTRADA ÁGUA	29	* 75311R0036	COBERTURA DE INVERNO
24	75311R0029	SENSOR TEMPERATURA AMBIENTE	29	* 75313R0036	COBERTURA DE INVERNO
25	75311R0030	SENSOR TEMPERATURA EVAPORADOR	30	75311R0034	BOCAL DE ÁGUA
26	75311R0031	SENSOR TEMPERATURA DESCARGA GÁS	31	75311R0033	MANGUEIRA DE DRENAGEM
27	75311R0032	CONJECTIVOS CONEXÃO DE ÁGUA			

* VEJA A FICHA DE OBSERVAÇÕES

ITEM

REV.: 0

1645

DATA: 21/12/2021

FOLHA: 3/3

CODIGO **75311, 75312, 75313**DESCRIÇÃO: **BOMBA DE CALOR FSN-08-10-12**

OBSERVAÇÕES

POS	CODIGO	OBSERVAÇÕES
2	* 75311R0018	PARA: 75311, 75312
2	* 75313R0018	PARA: 75313
6	* 75311R0015	PARA: 75311, 75312
6	* 75313R0015	PARA: 75313
7	* 75311R0014	PARA: 75311, 75312
7	* 75313R0014	PARA: 75313
8	* 75311R0013	PARA: 75311, 75312
8	* 75313R0013	PARA: 75313
12	* 75311R0009	PARA: 75311, 75312
12	* 75313R0009	PARA: 75313
14	* 75311R0006	PARA: 75311
14	* 75312R0006	PARA: 75312
14	* 75313R0006	PARA: 75313
16	* 75311R0004	PARA: 75311, 75312
16	* 75313R0004	PARA: 75313
19	* 75311R0001	PARA: 75311, 75312
19	* 75313R0001	PARA: 75313
29	* 75311R0036	PARA: 75311, 75312
29	* 75313R0036	PARA: 75313